

Original article

## Development and evaluation of a laboratory scale conch for chocolate production

Andrea Bordin Schumacher,\* Adriano Brandelli, Erwino Wulf Schumacher, Fernanda Carrion Macedo, Luiza Pieta, Tãmmila Venzke Klug & Erna Vogt de Jong

Instituto de Ciência e Tecnologia de Alimentos, Universidade Federal do Rio Grande do Sul (UFRGS), Av. Bento Gonçalves 9500, 91501-970 Porto Alegre, Brasil

(Received 24 June 2008; Accepted in revised form 8 October 2008)

**Summary** In this study a laboratory scale conch was developed with the purpose of testing new formulations using small amounts of chocolate mass. The equipment was built with working parts of others machines and the chocolate manufactured with the conch was evaluated in relation to the viscosity, moisture, acidity and polyphenol concentration. The resulting chocolate was tempered and then evaluated by a sensory panel. The results were always compared with an industrial conching process. The material used in the assays was dark chocolate (40% cocoa). Data were submitted to variance analysis (ANOVA) and when there was significant difference among the averages, the Tukey's test was applied. It was verified that the reduction of moisture and viscosity of the mass in the laboratory scale was similar to industrial scale. The parameters acidity and polyphenols showed no significant alterations when comparing both process scales. However, in the sensory analysis a flavour difference between the processing scales was perceptible.

**Keywords** Acidity, chocolate, cocoa, polyphenols.

### Introduction

The chocolate production basically consists of five stages: mixture of ingredients, refining, conching, tempering and final crystallisation. For production of high quality chocolate, not only the quality of the ingredients defines the final product. Besides, there is a great influence of the productive process, the formulation, and the regional expectations in relation to this product (Cidell & Alberts, 2006).

The solid ingredients are initially mixed with part of the cocoa butter to obtain a mass with the adequate consistency to be refined. The refining process must result the correct particle size (Bolenz *et al.*, 2003). Thus, the main goal of this stage is to reduce sugar crystals and solids of the cocoa to the size that it cannot be detected in the mouth (Lucisano *et al.*, 2006). Reaching the standardised particle size, the mass that became a fine powder is placed inside of a conch. The function of the conch was initially attributed to reduce the particle size and to guarantee the fluidity of the mass. However, after the development of refine machines this function started to be secondary, and then flavour modification is credited to the conching (Beckett, 1994). In the conch the undesirable flavours are suppressed and the pleasant

ones are produced, generating the typical flavour of the chocolate (Lucisano *et al.*, 2006).

Conching influences the development of flavour and the flow properties, being a process that occurs in three steps. In the dry phase, the refined product is warmed, blended and aerated, to evaporate the water and some acids originated from the cacao liquor (residues of the fermentation). In the pasty phase, where some melted cacao butter is added, some flavour precursors are produced to generate the typical flavour of chocolate. In the final liquid phase, all the particles are covered with a thin layer of fat that will result in a decrease of viscosity, which is very important for sensory characteristics of the chocolate. The lecithin is added in the liquid phase finishing the conching process (Beckett, 1994; Bolenz *et al.*, 2003).

Mainly for dark chocolates the time of conching influences in the flavour development and still today the majority of milk and dark chocolates are processed during 5–12 h (Bolenz *et al.*, 2003). Imperfections in the conching process may result inadequate distribution of the fat on solid particles generating a heterogeneous chocolate, migration of fat and sugar, acid flavour, and absence of desirable flavours. Thus, an adequate conching time will result in proper sensory characteristics, and it has been established in Swiss that the chocolate must be conched during 72 h (Cidell & Alberts, 2006).

\*Correspondent: Fax: +5551 3308 7048;  
e-mail: andrea.b.schumacher@hotmail.com

Chocolate production requires diverse controls for each unit operation. For testing new ingredients, to optimise processes, and to develop new products, some stages of chocolate production can be developed in industrial scale or in manually form. In an industrial refine machine it is possible to refine small amounts of products and the final tempering of the chocolate can be manually carried out on cold surfaces. However, for the conching of a small amount of mass, an apparatus with a proper size is required. In this study, a laboratory scale conch was developed to test new formulations using small amounts of chocolate mass. The equipment was assembled with working parts of other machines. The product elaborated in the laboratory conch was chemically and sensorially evaluated.

## Materials and methods

### Development of a laboratory scale conch

The laboratory scale conch was built based on industrial conch (Meteor S/A, São Paulo, Brazil), using equipment and parts of other machines. The laboratory conch was planned in three parts (Fig. 1). Firstly, a thermostatic bath used for common processes to melt chocolate was adapted. This equipment was composed of an external aluminum recipient with a resistance and a thermostat (Tonini, São Paulo, Brazil) and an internal stainless steel recipient with volume of 9 L. Soybean oil was placed inside of the thermostatic bath and the stainless steel recipient was fixed into the equipment. The thermostat

has regulation ranging from 20 to 120 °C. The second part was the elaboration of a mixer. In a metallic support it was fixed a structure composed by a 3-phase induction motor of 384 W (model B5K43MG15; General Electric, Santo André, Brazil), a speed dropbox, a pulley with 34 cm i.d., a belt Goodyear A57, two belts Goodyear ZX785 and a support with mandrill for setting tool (withdrawn from a bench drill). In the third stage, a set of impellers (to be connected in the support with mandrill) were elaborated. Two stainless steel impellers were developed: the first was a yoke-type and the second a propeller-type (Fig. 1). The distance between impellers and wall/bottom can be adjusted in accordance with the position inside the mandrill. When the impellers were placed for the experiments the distance was of approximately 2 mm. The thermostatic bath was fixed under the mixer and the impellers are used in agreement to the stage of the conching process. To define the heating procedure of the laboratory scale conch the temperature of soybean oil was checked at different temperatures of the thermostat.

### Conching process

The laboratory and industrial scale conching were composed by three phases: (1) dry phase lasted 6 h searching to reach temperatures of 70–5 °C; (2) pasty phase lasted 5 h diminishing the temperature (75–60 °C); (3) final phase lasted 1 h with decrease of temperature from 60 to 45 °C. The industrial machine is a rotatory conch with capacity of 3000 kg (TCR31;

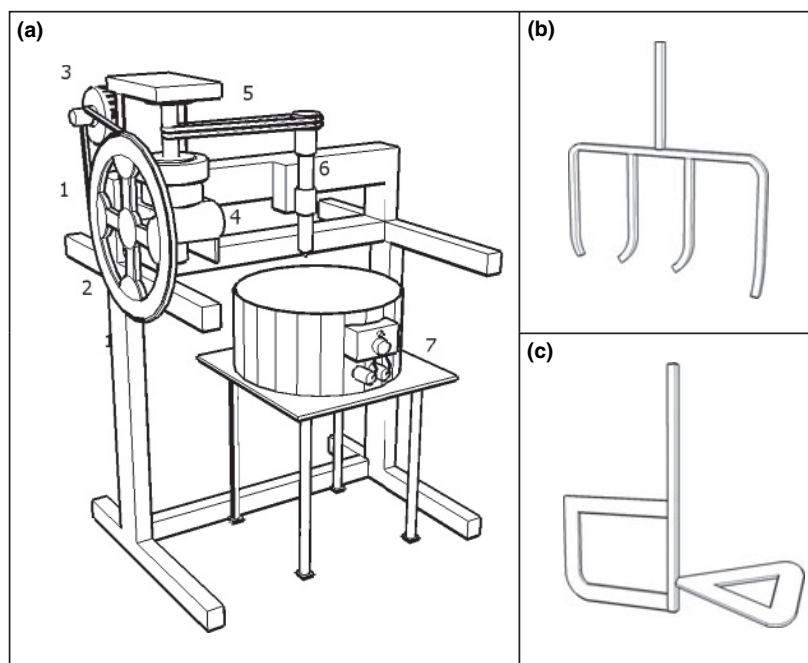

**Figure 1** The laboratory scale conch project. (a) General scheme of the equipment showing seven principal parts: (1) leather strap A57, (2) pulley, (3) induction motor, (4) speed dropbox, (5) leather straps ZX785, (6) axle with mandrill and (7) thermostatic bath; (b) yoke-type impeller; (c) propeller-type impeller.

Meteor S/A, São Paulo, Brazil). The conch is warm for double-jacket system with water circulation. The equipment has two internal axles with impellers, they turn in opposing directions with agitation at 20 r.p.m. The laboratory conch axle turns at 33 r.p.m.

A standard formula of Florestal Alimentos S/A containing the following ingredients was used: sugar, cocoa liquor, cocoa butter, whey powder, soybean lecithin, polyglycerol polyricinoleate and vanillin. Sugar, cocoa liquor, whey powder and 45.8% of the total cocoa butter were mixed, and then the mass was processed in a 5-roll refiner (Buhler, Uzwil, Switzerland). The remaining portion of cocoa butter was added to the conch: 28.2% in the dry phase and 26% in the liquid phase. Conching initiated with refined mass and the same additions (cocoa butter, emulsifiers and flavour) had been proportionally made during the process. To evaluate quality parameters, size distribution of chocolate particles was determined using a micrometer (Mitutoyo, Tokyo, Japan). The viscosity of the chocolate mass ( $40 \pm 0.1$  °C) was measured through a rotational viscometer (Model RVF; Brookfield Engineering Laboratories, Stoughton, MA, USA) with spindle 4 and rotation 4.

#### Evaluation of laboratory scale conch

Four conching experiments had been made. Each experiment was carried out at the same day in laboratory and industrial scales, with the same previously refined product. Samples of chocolate mass had been collected in the following intervals: 0 (refined product), 5, 6, 8.5, 11 and 12 h.

The first experiment (EXP01) was performed to obtain a preliminary set of results, and then verify the necessities for modifications in the laboratory conch. The second and third experiments (EXP02 and EXP03) were performed to evaluate the conching process. The last experiment (EXP04) had the purpose to obtain samples for sensory analysis.

#### Composition analysis

Moisture content of each sample was determined by a RVT 220 vacuum dryer (Hereaus, Hanau, Germany) at 70 °C and 6.6kPa (Kim *et al.*, 1999; Bolenz *et al.*, 2005) until constant weight for at least 7 h. Total acidity was measured by the titrimetric method (AOAC, 1990). The protein concentration was determined by semi micro-Kjeldahl method (AACC, 1995) and nitrogen to protein conversion factor of 5.75 was used. Fat content was measured by Soxhlet extraction, following acid hydrolysis (AOAC, 1990). Ash content was determined at 550 °C in an oven (AOAC, 1990). Total carbohydrates were determined as the difference between 100% and the sum of the other components (proteins, lipids, ash, fibre

and moisture). The analyses were carried out in duplicate, and the values were averaged.

#### Determination of polyphenol concentration

The method described by Vinson *et al.* (1998) with minor modifications was used for preparation of the samples and the analysis was carried out in triplicates. The samples were weighed (100 mg), grinded and defatted by three sequential extractions with hexane. Samples were dried and 50 mg were mixed with 5 mL of  $1.2 \text{ mol L}^{-1}$  of HCl in 50% (v/v) methanol and heated for 2 h at 90 °C. Samples were mixed every 30 min.

An aliquot (100 µL) of chocolate extract was mixed with 1 mL of Folin Ciocalteu's reagent diluted 1:9 (v/v) with distilled water (Vinson *et al.*, 2001). After 20 min the colour was measured at 750 nm using a Shimadzu UV mini1240 spectrophotometer (Shimadzu, Tokyo, Japan). A standard curve was prepared from a 1000 µM stock solution of pirocatechin (Vetec, Rio de Janeiro, Brazil).

#### Sensory analysis

After conching, the chocolate mass obtained from the different processes had been melted, tempered and molded. Twenty-six non-trained panelists evaluated the samples, using the Triangle Test. Half of the group received two samples from laboratory scale conch and one sample of the industrial scale conch and the other group received the opposite.

#### Statistical analysis

Statistical significance between the samples was performed using one-way ANOVA and comparisons between means were performed by Tukey's test. Results were considered different each other at the significance level of 99% ( $P < 0.01$ ).

## Results and discussion

#### The laboratory scale conch

Laboratory conching process could be compared with an industrial conching and therefore the procedures must be similar. For this propose, the procedure was to maintain the thermostat at 90 °C in the dry phase (mass at  $70 \pm 10$  °C); 90 °C in the pasty phase, besides changing to 60 °C at the 10th hour (mass at  $50 \pm 10$  °C) until the final phase. In the industrial equipment the mass cooled from 75 to 60 °C during 5 h of pasty phase. In laboratory scale conch the cooling was faster, considering the small capacity of the equipment. For this reason, the pasty phase had the temperature of the thermostat maintained at 90 °C for more

time. It was possible to conch 1.2-kg chocolate in the laboratory scale with minimal product loss. The industrial conch used in this study processed 3 tonnes of chocolate mass.

The diagram of the laboratory machine is demonstrated in the Fig. 1. The constructed impellers to adapt in the laboratory conch mixer can be seen in Fig. 1. The propeller-type impeller is similar to the industrial conch mixer, but it was verified that this type did not promote a suitable mixture during the first two phases. In the dry phase the yoke-type functioned very well. The mass showed similar visual aspect to the industrial product in this phase. In the pasty phase, both impellers showed reasonable results. It was observed that the yoke-type impeller had better performance in the beginning and the propeller-type in the end of the phase. The propeller-type impeller had better performance for low-viscosity mass.

#### Evaluation of the conching process

The moisture reduction in the EXP01 for both industrial and laboratory processes is illustrated in Fig. 2a. Excepting at 12 h, no significant differences were observed in the moisture values between the processes. Bolenz *et al.* (2005) describe as acceptable the moisture values of 0.4–0.6% in the end of conching. Indeed, in the industrial conch the loss of water occurred earlier, but subsequently in equilibrium with the air humidity the chocolate will increase this value. The water enters in the product through the empty spaces of fat crystals. When the moisture reaches the sugar or cocoa solids, result that this water is absorbed (Ghosh *et al.*, 2005). Increased water amount may cause migration of these ingredients to the chocolate surface. For this reason the moisture control is very important in the chocolate processing.

The chocolate mass from the laboratory conch showed higher viscosity (19 000 cP vs. 11 600 cP for industrial product), which can be associated with the higher humidity at the end of the process. This occurs because the rheological properties of chocolate depend on water content (Bolenz *et al.*, 2005; Sokmen & Gunes, 2006). In addition, the high viscosity at the end of the laboratory scale process could be caused by the slipping of the belt ZX785 during the EXP01. This fact generated the necessity of manipulation of the mass with spatulas. After this verification, it was necessary to add a second belt ZX785. Thus, the problems with the use of a single belt may have negatively influenced the viscosity. The correct particle covering by fat depends on the vigour of the mixture in the conch. Servais *et al.* (2004) describes that any disturbance of the chocolate mass may affect the viscosity, as well as the amount of moisture, temperature, and all operations of chocolate processing.

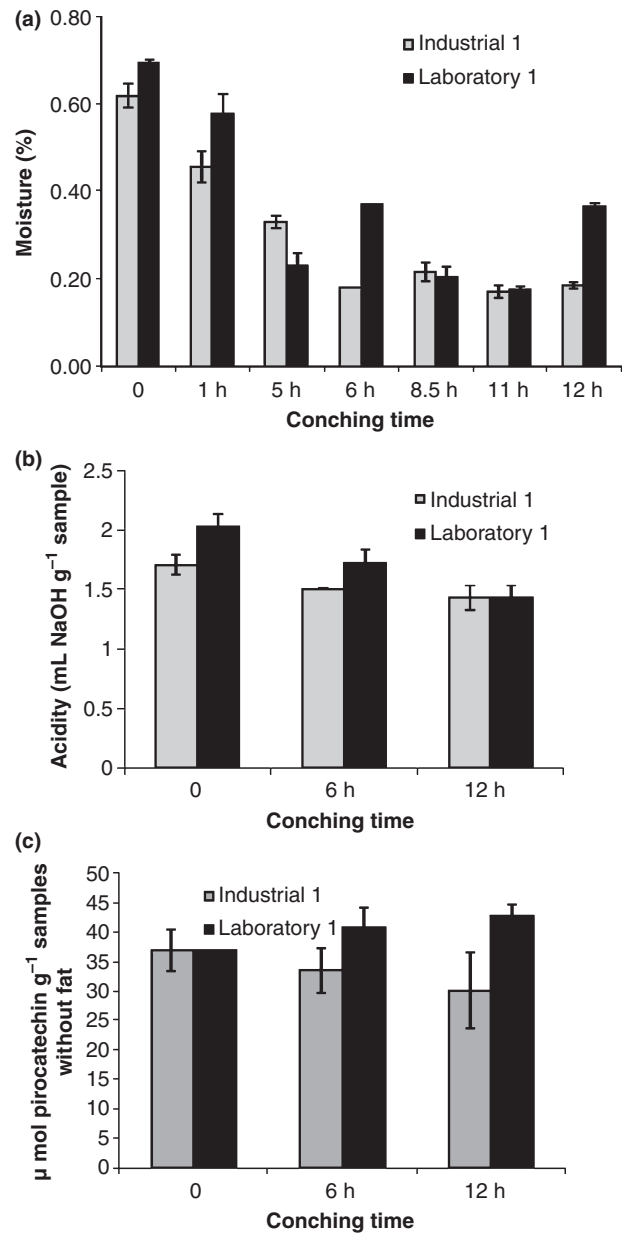

**Figure 2** Variation of the moisture (a), acidity (b) and polyphenol concentration (c) in the EXP01, comparing industrial (grey bars) and laboratory (black bars) scale processes. Data are means  $\pm$  SEM of duplicate assays.

Particle size above 35  $\mu\text{m}$  often results a coarse mouthfeel, although the acceptance interval for this quality parameter changes for each region (Sokmen & Gunes, 2006). Normally values around 20  $\mu\text{m}$  are used as standard (Cohen *et al.*, 2004), which corresponded to the particle size obtained in the EXP01 for both industrial and laboratory product. In this case, the homogeneity of the refined flakes is a relevant factor,

thus the same particle size did not interfere with viscosity. Therefore, the smaller the particle size, the higher the plastic viscosity, because it increases the contact surface with the cocoa butter (Sokmen & Gunes, 2006).

The values of acidity in EXP01 can be observed in Fig. 2b. The values of acidity were similar among the different time and no significant differences were observed between the final acidity of the two processes.

Beckett (1994) reported that the concentration of phenolic compounds diminishes after 24 h of conching and it is well known that polyphenols, through oxidation and enzymatic mechanisms form complexes with amino acids, peptides and proteins (Friedman, 1996). The polyphenol concentration in EXP01 was determined, and the differences among the different time and processes were not significant at  $P < 0.01$  (Fig. 2c). However, lower mean value and a larger standard deviation were observed for the industrial sample with 12 h conching. Despite this difference, all values were comparable with those described to chocolate (Vinson *et al.*, 1999; Miller *et al.*, 2006).

The values of chocolate composition can be observed in Table 1. Differences were not significant. It is important to give attention for the increase of the moisture in the two products after they had been melted, tempered, molded and directed to analyses.

For the subsequent runs (EXP02, EXP03 and EXP04), the yoke-type impeller was used during the first 9 h. This corresponds to all dry phase and the beginning of pasty phase in the laboratory scale conch. Another impeller was used until the end of the process. A second leather strap ZX785 was placed so that the viscosity of the mass was not affected by stops in the mixture.

The moisture variation of EXP02 and EXP03 can be verified in the Fig. 3. The differences in the moisture values between each one of the experiments, at each analysed interval, were not significant ( $P > 0.01$ ). In the industrial scale an important moisture reduction can be observed at 5 and 6 h followed by an increase in the subsequent points. It is possible to explain this fact because the industrial pasty phase started the reduction of the temperature but the great amounts of mass

**Table 1** Chocolate composition of EXP01

	Industrial 1	Laboratory 1
Fat	26.06 ± 1.626 <sup>a</sup>	27.82 ± 1.039 <sup>a</sup>
Ash	1.36 ± 0.073 <sup>a</sup>	1.37 ± 0.015 <sup>a</sup>
Protein	3.48 ± 0.013 <sup>a</sup>	3.45 ± 0.013 <sup>a</sup>
Moisture	0.80 ± 0.007 <sup>a</sup>	0.67 ± 0.064 <sup>a</sup>
Carbohydrate	68.30 ± 1.693 <sup>a</sup>	66.70 ± 1.101 <sup>a</sup>

Values followed by different letters in the same row differ significantly ( $P < 0.01$ ).

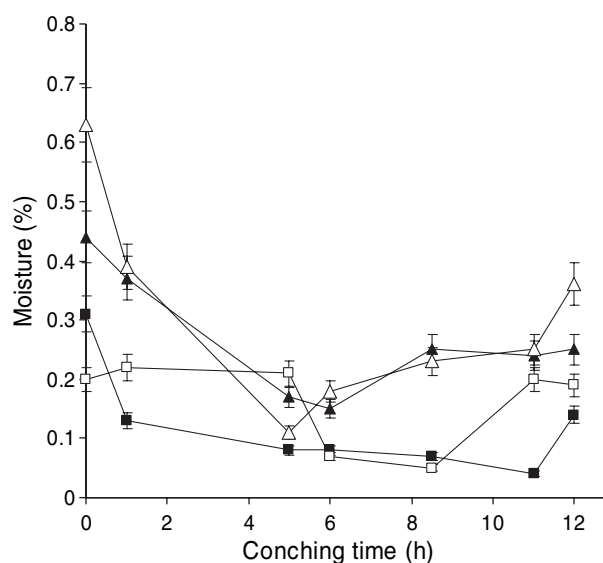

**Figure 3** Moisture of chocolate mass for the period of conching. Moisture was monitored during industrial (triangles) and laboratory scale (squares) conching in both EXP02 (black symbols) and EXP03 (open symbols). Data are means ± SEM of duplicate assays.

**Table 2** Quality parameters EXP02 and EXP03

	Industrial 2	Laboratory 2	Industrial 3	Laboratory 3
Particle size (µm)	20	21	19	18
Viscosity (cP)	10 000	10 200	9000	11 400

maintain at high temperature reducing slowly until the 11th hour.

It was verified that the particle size and viscosity had very close values indicating the similarity of the laboratory and industrial processes (Table 2). During the operation of laboratory scale conch it was verified that the presence of a second leather strap ZX785 improved the quality of the mixture. The control of viscosity allows the control of process parameters such as weight, quality of molding, quality of covering formation in the industry process (Servais *et al.*, 2004).

It was expected that conching can reduce the acidity of the mass during the process. Bolenz *et al.* (2005) describes that nowadays the improvement of the cocoa liquor results ingredients of high quality and low acidity. The acidity values of the EXP02 and EXP03 can be seen in the Table 3. Acidity diminished during the conching, although in the industrial process the differences were not significant. Evaluating the laboratory conch, significant decrease in the values of acidity was observed during the process in both EXP02 and EXP03 (Table 3). No significant differences in acidity values were observed between laboratory and industrial scale at

**Table 3** Variation of the acidity in the EXP02 and EXP03

Time (h)	Acidity (mL of NaOH g <sup>-1</sup> )			
	Industrial 2	Laboratory 2	Industrial 3	Laboratory 3
0	1.72 ± 0.08 <sup>a</sup>	2.03 ± 0.107 <sup>a</sup>	0.90 ± 0 <sup>a</sup>	0.98 ± 0.106 <sup>a</sup>
6	1.50 ± 0.004 <sup>a</sup>	1.73 ± 0.106 <sup>b</sup>	0.75 ± 0 <sup>a</sup>	0.75 ± 0 <sup>b</sup>
12	1.43 ± 0.107 <sup>a</sup>	1.43 ± 0.106 <sup>c</sup>	0.75 ± 0 <sup>a</sup>	0.68 ± 0.107 <sup>b</sup>

Values followed in the same column by different letters differ significantly ( $P < 0.01$ ).

12th hour. The differences in acidity could reflect the impact of different cocoa liquors, as high acid EXP02 decreases much more than low acid EXP03. It has been described that roasting reduces the acidity of cocoa liquor as evidenced by significant decrease in the concentration of volatile acids, particularly acetic acid (Misnawi *et al.*, 2004). In this regard, a minor amount of volatile acids could be associated with the observed results.

The polyphenol concentration of the chocolate mass obtained in EXP02 and EXP03 was determined, demonstrating that a reduction in the amount of polyphenols occurred during the conching, although significant differences were not observed (Table 4). The processing of food containing high amount of cacao is susceptible to the reduction of the amount of polyphenols and this should be prevented as a result of their potential beneficial health effects, mainly in relation in cardiovascular diseases (Lee *et al.*, 2003; Engler & Engler, 2004; Barberán *et al.*, 2007). However, increased polyphenol concentration in cocoa liquor may result in decreased cocoa flavour and increased astringency and bitterness (Misnawi *et al.*, 2004).

### Sensory analysis

An additional experiment (EXP04) was developed aiming the sensory evaluation of the chocolate produced by both processes. Particle size was determined as 20 µm in both industrial and laboratory mass. It was also verified that viscosity remained similar in fully acceptable values for production of dark chocolate. The values

**Table 4** Variation of the polyphenols in the EXP02 and EXP03

Time (h)	Polyphenol (µmol pirocatechin/g)			
	Industrial 2	Laboratory 2	Industrial 3	Laboratory 3
0	36.49 ± 1.997 <sup>a</sup>	39.97 ± 0.441 <sup>a</sup>	32.42 ± 3.145 <sup>a</sup>	37.18 ± 1.444 <sup>a</sup>
6	33.04 ± 3.901 <sup>a</sup>	40.88 ± 0.438 <sup>a</sup>	29.98 ± 2.274 <sup>a</sup>	29.68 ± 0.169 <sup>b</sup>
12	28.63 ± 1.215 <sup>a</sup>	37.52 ± 3.246 <sup>a</sup>	28.63 ± 1.215 <sup>a</sup>	30.67 ± 2.644 <sup>ab</sup>

Values followed by different letters in the same column differ significantly ( $P < 0.01$ ).

**Table 5** Chocolate composition of EXP04

EXP 04	Industrial 4	Laboratory 4
Fat	27.95 ± 0.990 <sup>a</sup>	28.11 ± 0.134 <sup>a</sup>
Ash	1.21 ± 0.042 <sup>a</sup>	1.20 ± 0.127 <sup>a</sup>
Protein	3.51 ± 0.039 <sup>a</sup>	3.65 ± 0.0151 <sup>a</sup>
Moisture	1.00 ± 0.050 <sup>a</sup>	0.97 ± 0.120 <sup>a</sup>
Carbohydrate	66.34 ± 0.130 <sup>a</sup>	66.08 ± 0.142 <sup>a</sup>

Values followed in the same line by different letters differ significantly ( $P < 0.01$ ).

were 9200 and 10 800 cP for industrial and laboratory products respectively. Sample composition (EXP04) had been determined to guarantee similarity of both products. The values can be seen in the Table 5.

Significant sensory difference was verified between the samples produced in the laboratory conch and industrial conch. Amongst the panelists that had perceived difference, some part observed difference in flavour; however most did not describe this difference. Within the group that verified differences between the laboratory and industrial samples, 38.5% indicated the presence of residual flavour, but only one panelist indicated this residual flavour as caramel flavour. In this same group, only one participant told that the laboratory sample presented a brittle texture, but this commentary was strengthened by other two participants who indicated that industrial sample was softer than other.

Of the complete sensory panel, 64% preferred the sample elaborated in the industrial conch. The alteration in the flavour of the sample produced in pilot scale could be related with two factors: (a) oscillation of thermostat temperature ( $\pm 10$  °C) and (b) the small amount of product in the laboratory conch. Both factors may have contributed for caramel flavour development in the product. Response to caramel is cultural; a strong caramel flavour is not desired by central European consumers (Bolenz *et al.*, 2005). Although Brazilian consumers do no dislike it, the difference between laboratory and industrial product was noted by the sensory panel. Beckett (1994) argues that in the pasty phase it is relevant to avoid large variations in the temperature, therefore this generates important alterations in the flavour. Heat transfer in a laboratory scale conch is bigger than on an industrial scale and this occurs because the decreased relative heating surface in large conches (Bolenz *et al.*, 2005).

### Conclusions

The laboratory scale conch results a product with similar characteristics to that obtained with an industrial conch when compared in relation with humidity and acidity reduction, polyphenol concentration and final

mass viscosity. However, some limitations need to be identified, as the products from laboratory and industrial conch showed sensory differences. A possible cause for the residual flavour formation in the laboratory conch was the large temperature variation, being able to generate overheating, which directly modifies the flavour of the chocolate.

This work showed that it was possible to construct an inexpensive machine of great importance for development of new chocolate products, recycling parts of disused machines. Without making the necessary modifications to the heating system, this laboratory conch could not be used in tests of flavour evaluation, excepting if the purpose will not be comparative with the industrial scale. With the heating procedure and thermostat used in this work, tests involving modifications in chocolate formulae can be made in the laboratory conch.

### Acknowledgments

Authors thank Tatiana Pereira Dias de Castro for the elaboration of Fig. 1 and Florestal Alimentos S/A for supplying the chocolate used in this study. This work was supported by CAPES, Brazil. A. Brandelli is research awardees of CNPq, Brazil.

### References

- American Association of Cereal Chemistry (AACC), 46-13. Crude Protein-Micro Kjeldhal method. St Paul, USA: AACC.
- Association of Official Analytical Chemists (1990). *Official Methods of Analysis*, 15 edn. *Fat in Cacao Products: Soxhlet Extraction Method (963.15)*. Washington: AOAC.
- Barberán, F.A.T., Jovellanos, E.C., Marín, A. *et al.* (2007). A new process to develop a cocoa powder with higher flavonoid monomer content and enhanced bioavailability in healthy humans. *Journal of Agricultural and Food Chemistry*, **55**, 3926–3935.
- Beckett, S.T. (1994). *Fabricación y Utilización Industrial del Chocolate*. Pp. 121–157. Zaragoza: Editorial Acirbia.
- Bolenz, S., Thiessenhusen, T. & Schape, R. (2003). Fast conching for milk chocolate. *European Food Research and Technology*, **218**, 62–67.
- Bolenz, S., Amsberg, K. & Lipp, E. (2005). New concept for fast continuous conching of milk chocolate. *European Food Research and Technology*, **220**, 47–54.
- Cidell, J.L. & Alberts, H.C. (2006). Constructing quality: the multinational histories of chocolate. *Geoforum*, **37**, 999–1007.
- Cohen, K.O., Luccas, V. & Jackix, M.N.H. (2004). Review: tempering or precrystallization of chocolate. *Brazilian Journal of Food Technology*, **7**, 23–29.
- Engler, M.B. & Engler, M.M. (2004). The vasculoprotective effects of flavonoid-rich cocoa and chocolate. *Nutrition Research*, **24**, 695–706.
- Friedman, M. (1996). Food browning and its prevention: an overview. *Journal of Agricultural and Food Chemistry*, **44**, 631–652.
- Ghosh, V., Ziegler, G.R. & Anantheswaran, R.C. (2005). Moisture migration through chocolate-flavored confectionery coatings. *Journal of Food Engineering*, **66**, 177–186.
- Kim, S.S., Kim, S.Y., Kim, D.W., Shin, S.G. & Chang, K.S. (1999). Moisture sorption characteristics of composite foods filled with chocolate. *Journal of Food Science*, **64**, 300–302.
- Lee, K.W., Kim, Y.J., Lee, H.J. & Lee, C.Y. (2003). Cocoa has more phenolic phytochemicals and a higher antioxidant capacity than teas and red wine. *Journal of Agricultural and Food Chemistry*, **51**, 7292–7295.
- Lucisano, M., Casiraghi, E. & Mariotti, M. (2006). Influence of formulation and processing variables on ball mill refining of milk chocolate. *European Food Research and Technology*, **223**, 797–802.
- Miller, K.B., Stuart, D.A., Smith, N.L. *et al.* (2006). Antioxidant activity and polyphenol and procyanidin contents of selected commercially available cocoa-containing and chocolate products in the United States. *Journal of Agricultural and Food Chemistry*, **54**, 4062–4068.
- Misnawi, S.J., Jamilah, B. & Nazamid, S. (2004). Sensory properties of cocoa liquor as affected by polyphenol concentration and duration of roasting. *Food Quality and Preference*, **15**, 403–409.
- Servais, C., Ranc, H. & Roberts, I.D. (2004). Determination of chocolate viscosity. *Journal of Texture Studies*, **34**, 467–497.
- Sokmen, A. & Gunes, G. (2006). Influence of some bulk sweeteners on rheological properties of chocolate. *LWT—Food Science and Technology*, **39**, 1053–1058.
- Vinson, J.A., Hao, Y., Su, X. & Zubik, L. (1998). Phenol antioxidant quantity and quality in foods: vegetables. *Journal of Agricultural and Food Chemistry*, **46**, 3630–3634.
- Vinson, J.A., Proch, J. & Zubik, L. (1999). Phenol antioxidant activity quantity and quality in foods: cocoa, dark chocolate, and milk chocolate. *Journal of Agricultural and Food Chemistry*, **47**, 4821–4824.
- Vinson, J.A., Proch, J. & Bose, P. (2001). Determination of quantity of polyphenol antioxidants in foods and beverages. *Methods in Enzymology*, **335**, 103–114.